

Model No:LZ-3528BIN2

Yellow TOP LED (1210)

Lead(Pb) Free Product-ROHS Compliant

■ Applications

1. Lightings
2. Modules
3. Signal and Symbol Luminaires
4. Backlighting
5. Toys

■ Package Dimensions

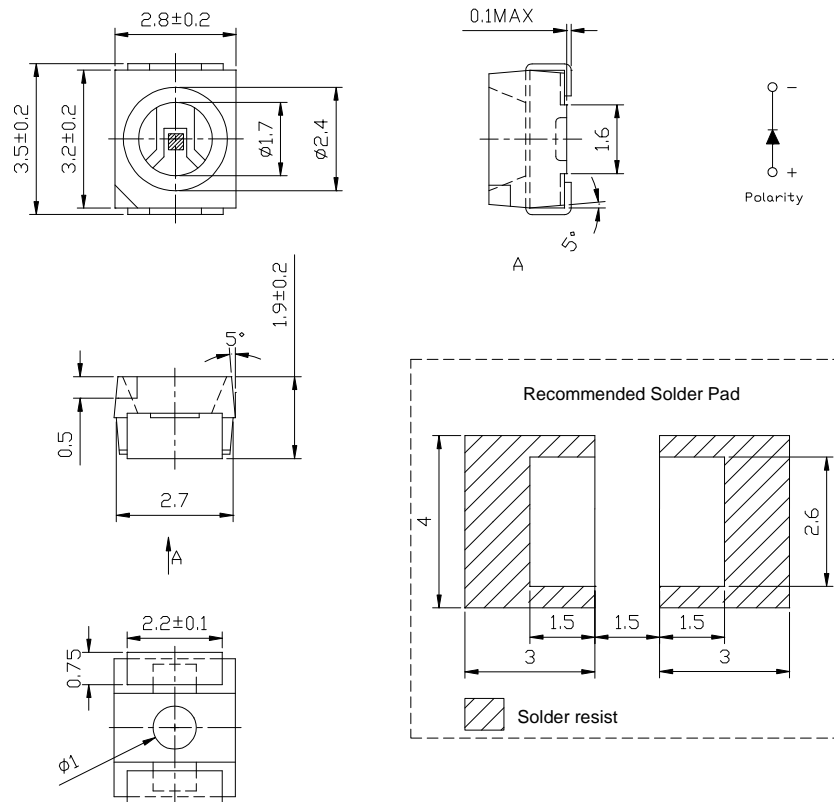

Notes:

All dimensions in mm tolerance is ± 0.1 mm unless otherwise noted.

■ Absolute Maximum Ratings (Ta = 25°C)

Items	Symbol	Absolute maximum Rating	Unit
Power Dissipation	P _D	80	mW
Forward Current(DC)	I _F	30	mA
Peak Forward Current*	I _{FP}	100	mA
Operation Temperature	T _{opr}	-40 ~ +95	°C
Storage Temperature	T _{stg}	-40 ~ +100	°C

*Pulse width ≤ 0.1msec duty ≤ 1/10

■ Typical Electrical & Optical Characteristics (IF=20mA and Ta = 25°C)

Part No	Dominant Wavelength (nm)		Forward Voltage (v)		Luminous Intensity (mcd)		Reverse Current (μA)	50% Power Angle
	Min.	Typ.	Min.	Typ.	Min.	Typ.	Max.	Typ.
LZ-3528BIN2	586	590	1.8	2.0	271	350	10	120

■ Ranks Combination (IF = 20mA)

Rank	T1	T2
Luminous Intensity(mcd)	400-541	271-350

■ Notes

1. Tolerance of measurement of luminous intensity : ±15%
2. Tolerance of measurement of dominant wavelength : ±1.0nm
3. Tolerance of measurement of forward voltage : ±0.1V

■ Typical Electrical/ Optical Characteristics Curves (Ta=25°C Unless Otherwise Noted)

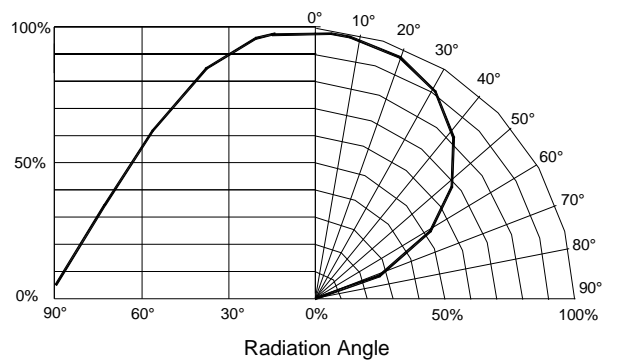
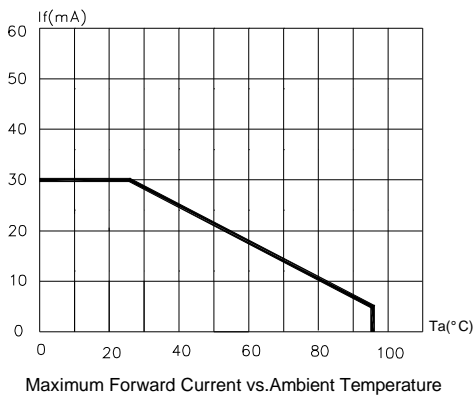
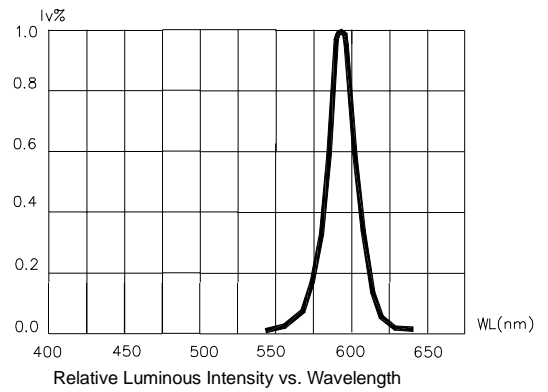
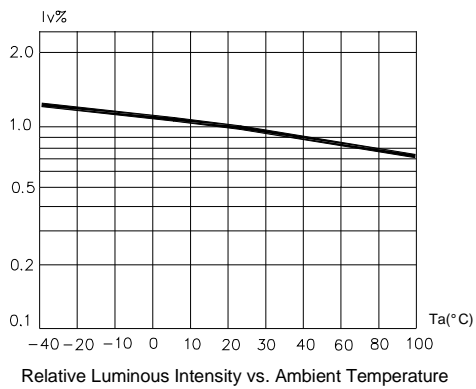
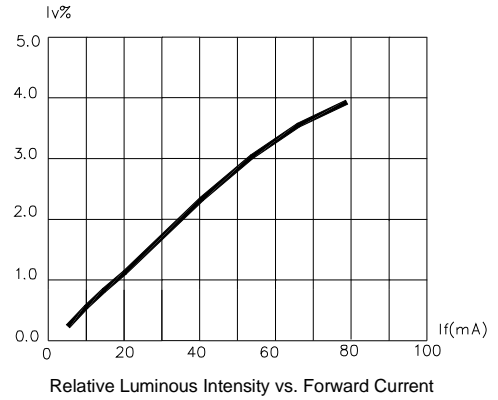
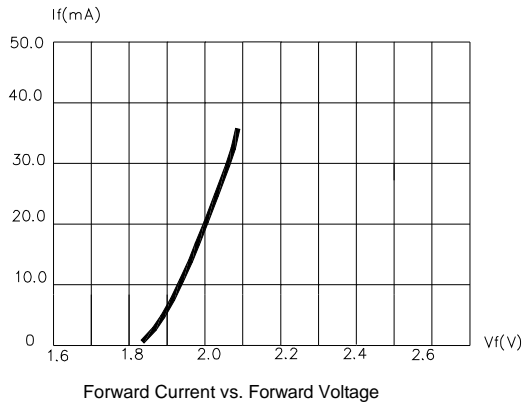

■ Soldering heat reliability:

Lead Solder

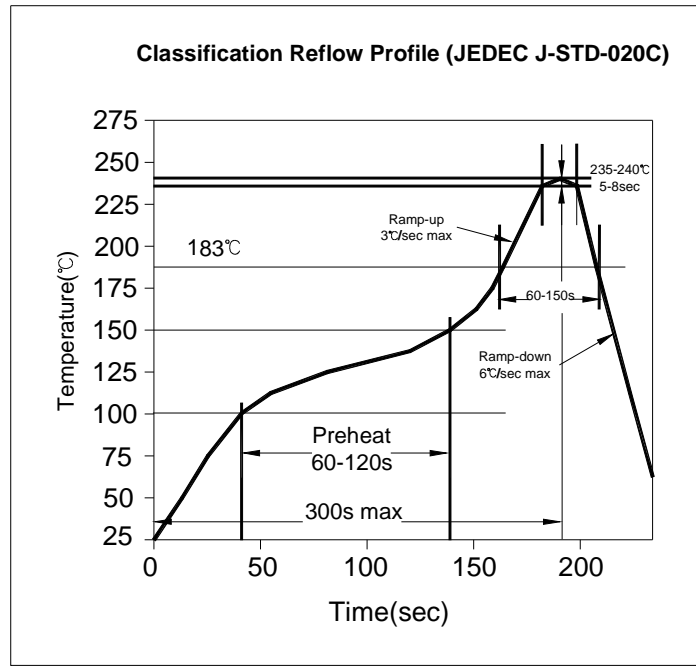

Lead Free Solder

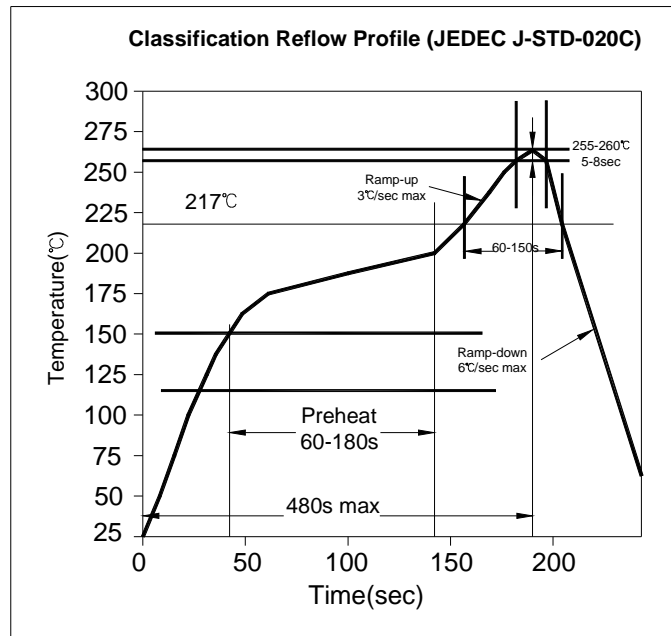

■ Packing Specifications:

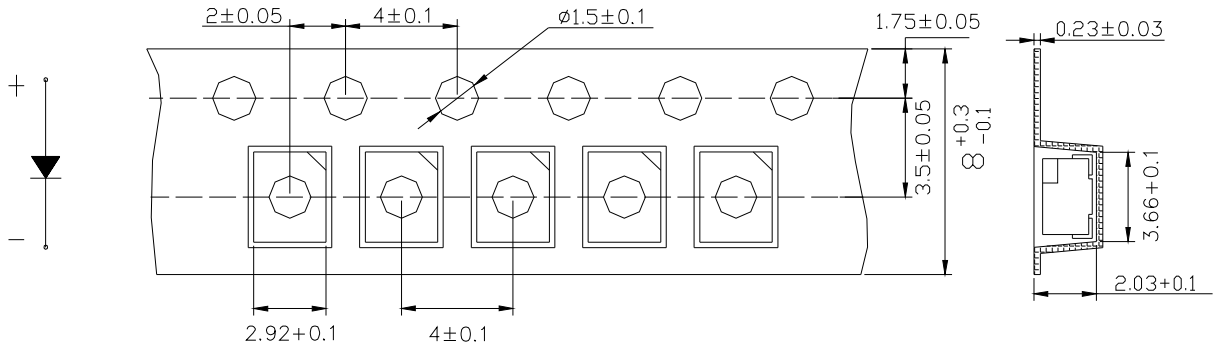

■ Reel Specifications

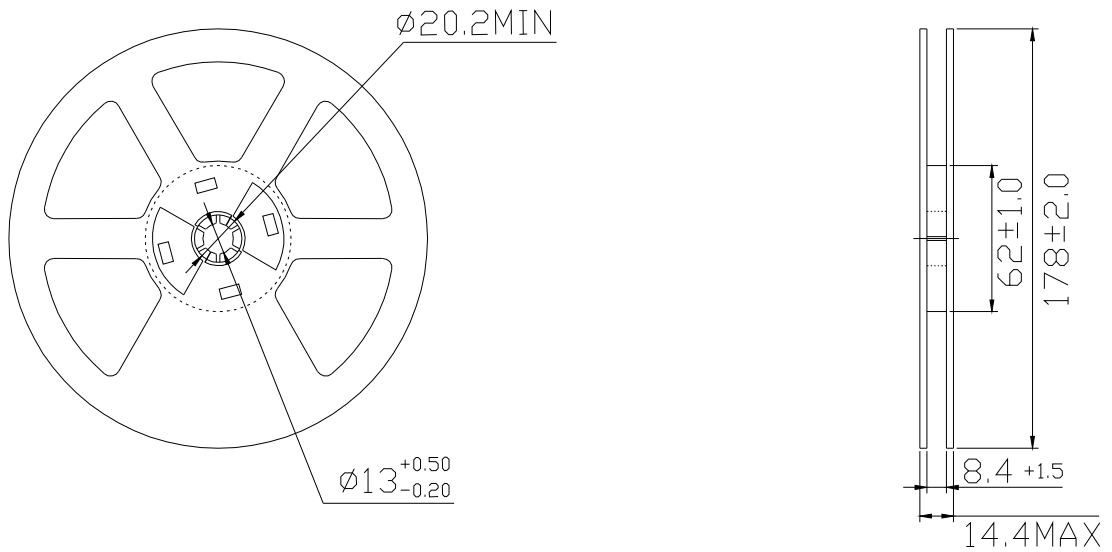

Dimensions are specified as follows: mm

Notes:

- 1) The packing only appropriate for LZGD
- 2) Normal packing quantity: 2,000pcs/reel

Revision History					
Rev.No.	Change Description	Date	Prepared By	Checked By	Approved By
Preliminary		2013/1/5	YQJ	Junney	Junney