

Model No:LZ-5054BIN2

Blue TOP LED (5050)

Lead(Pb) Free Product-RoHS Compliant

■ Applications

1. interior and exterior automotive lightings
2. Backlighting
3. illuminated advertising
4. Signal and Symbol Luminaires

■ Package Dimensions

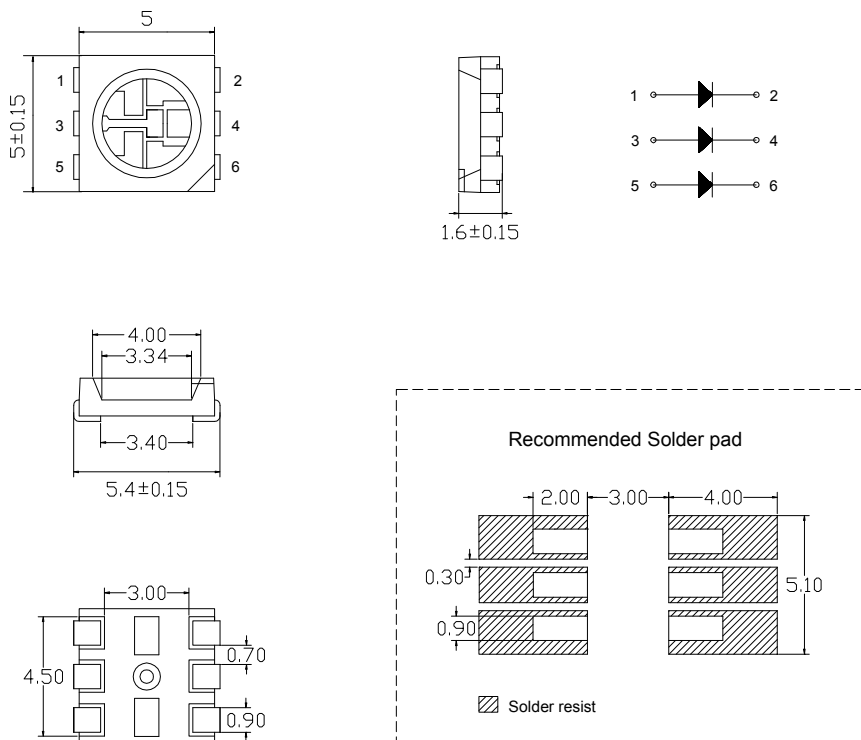

Notes:

All dimensions in mm tolerance is ± 0.1 mm unless otherwise noted.

■ Absolute Maximum Ratings (Ta = 25°C)

Items	Symbol	Absolute maximum Rating	Unit
Power Dissipation*	P _D	100	mW
Forward Current(DC)**	I _F	25	mA
Peak Forward Current***	I _{FP}	100	mA
Operation Temperature	T _{opr}	-30~ +95	°C
Storage Temperature	T _{stg}	-40 ~ +100	°C

*The Value is for one LED Circuit

**The Value is for one LED Circuit. For long term performance the drive currents between 5mA and 20mA are recommended(Three circuits are lit simultaneously). Please contact LZGD sales representative for more information on recommended drive conditions.

***Pulse width ≤ 0.1msec duty ≤ 1/10

■ Typical Electrical & Optical Characteristics (Ta = 25°C)

Items	Symbol	Condition	Min.	Typ.	Max.	Unit
Forward Voltage	V _F	I _F = 3*20mA	2.8	3.2		V
Reverse Current	I _R	V _R = 5V	---	---	50	μ A
Dominant Wavelength	λ _d	I _F = 3*20mA	464	470	---	nm
Luminous Intensity	I _V	I _F = 3*20mA	861	1000	---	mcd
50% Power Angle	2θ _½	I _F = 3*20mA	---	120	---	Deg

■ Ranks Combination (IF = 3*20mA)

Rank	T1	T2
Luminous Intensity(mcd)	1000-1239	861-1000

■ Notes

1. Tolerance of measurement of luminous intensity : ±15%
2. Tolerance of measurement of dominant wavelength : ±1nm
3. Tolerance of measurement of forward voltage : ±0.1V

■ Typical Electrical/ Optical Characteristics Curves (Ta=25°C Unless Otherwise Noted)

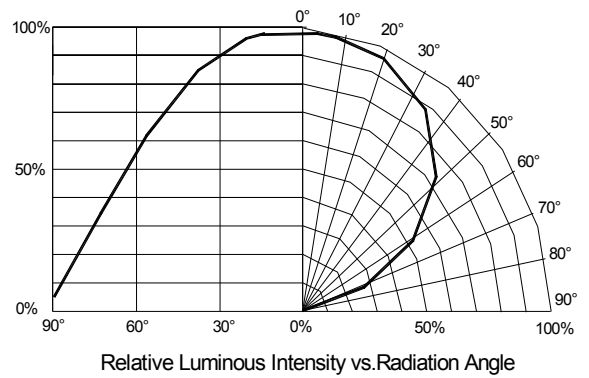
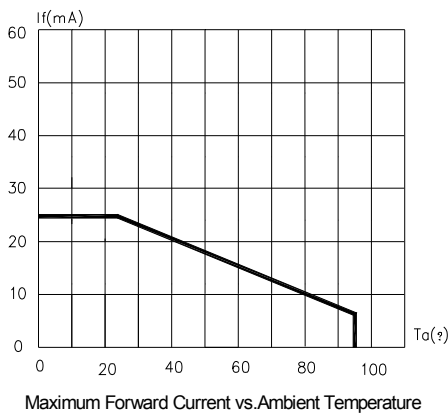
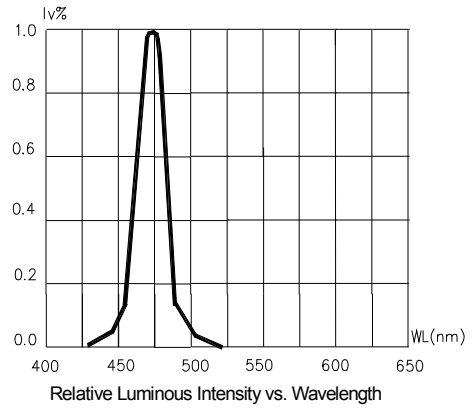
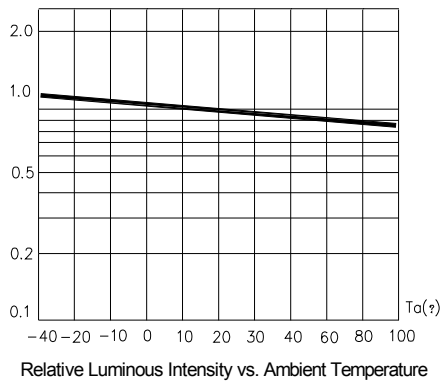
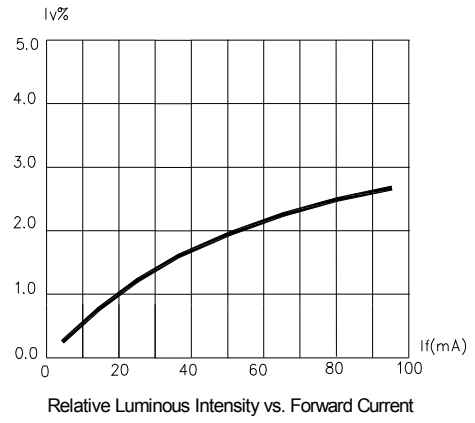
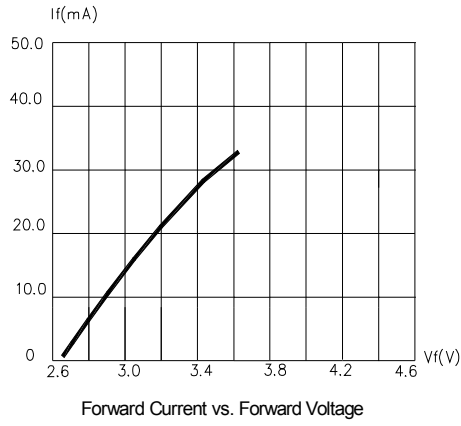

■ Soldering heat reliability:
Lead Solder

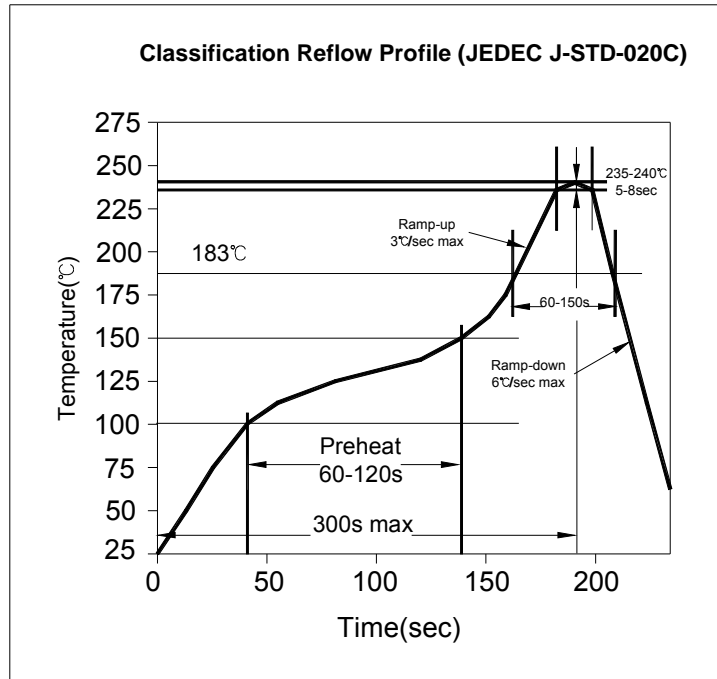

Lead Free Solder

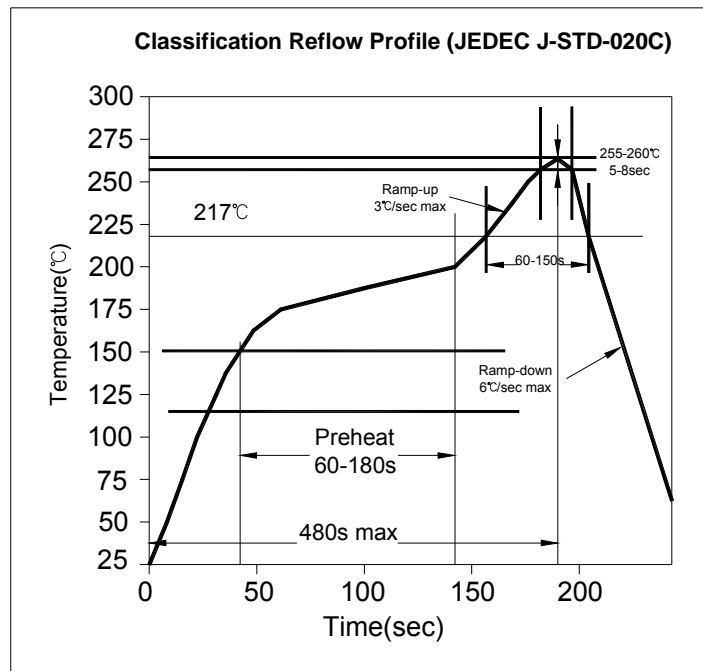

■ Packing Specifications:

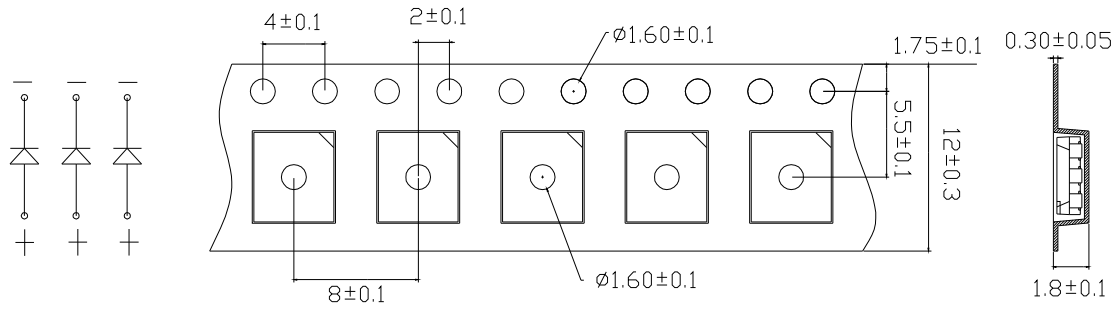

■ Reel Specifications

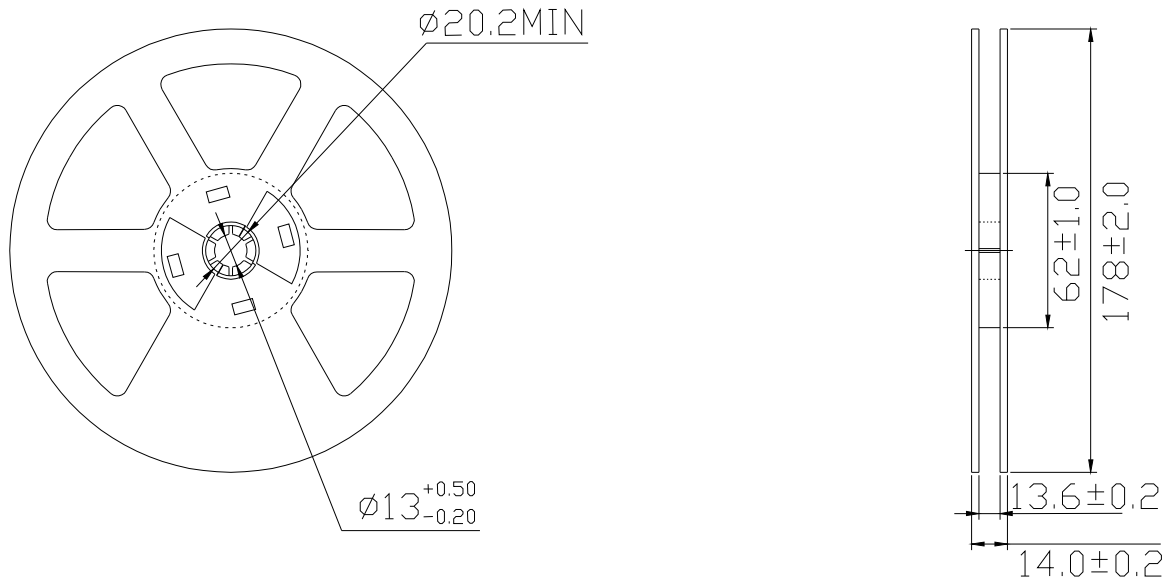

Dimensions are specified as follows:mm

Notes:

- 1) The packing only appropriate for LZGD
- 2) Normal packing quantity: 1,000pcs/reel

Revision History					
Rev.No.	Change Description	Date	Prepared By	Checked By	Approved By
Preliminary		2008/12/3	YQJ	Junney	Junney
01	Modified curve	2013/1/13	TJG	Junney	Junney